



FB420 Shaft Speed Sensor

- Compact, self-contained system with sensor and switch
- Simple installation and calibration
- Relay can be set for over-speed or under-speed
- Rugged housing is explosionproof and waterproof - NEMA 4X
- 4-20mA output directly proportional to shaft speed
- Provides real time preventive maintenance feedback
- Prevents product waste, machinery damage and process downtime



Product Information

Description

Electro-Sensor's FB420 is a shaft speed sensor that provides a 4-20mA signal directly proportional to the rotational speed of a monitored shaft. Since both the 4mA and 20mA calibration points are programmable the user can also operate the FB420 with the 4mA offset from 0 RPM. The FB420 has a 4 digit LCD display used for calibration and trouble-shooting. The LCD is capable of displaying from **0.000 to 9999. RPM** or from **04.00 to 20.00 mA**. The FB420 has one relay that can be programmed for failsafe over-speed alarm or failsafe under-speed alarm.

Housed in a rugged, explosionproof NEMA 4X housing, the FB420 is ideal for detecting shaft under-speed or over-speed on a wide variety of industrial machinery. Typical applications include belt conveyors, drag conveyors, bucket elevators, fans, blowers, crushers, and pumps. The FB420 is compatible with a wide range of pulser discs and wraps, and can be mounted using the optional EZ100 and stainless steel discguard when required. Electro-Sensors' products bring efficiency and safety to your operations by preventing machine damage, product waste and costly downtime.

Dimensional Drawings • FB420

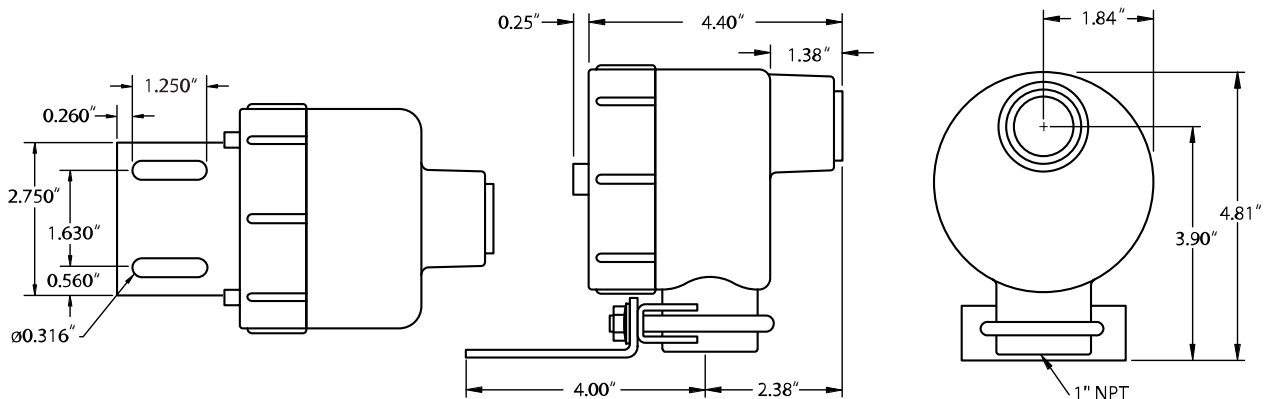

Pulser Disc

The end of the shaft to be monitored must be center drilled to a depth of 1/2-inch with a #21 drill and tapped for a 10-32 UNF. After applying Loctite™ or a similar adhesive on the threads to keep the pulser disc tight, the pulser disc should be attached, decal side out with the supplied 10-32 UNF machine screw and lock washer. Dimension (A) is 1/16 inch to 1/4 inch.

The center-line of the magnets (B) must align with the center of the sensing head as the Pulser disc rotates.

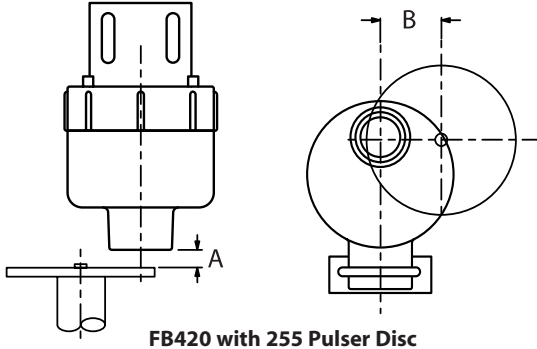

FB420 with 255 Pulser Disc

Pulser Wrap (optional)

Pulser wraps are custom manufactured to fit the shaft they will be mounted on. When the wrap is shipped, four Allen-head cap screws hold the two halves of the wrap together. These screws must be removed so the wrap is in two halves. Place the halves around the shaft, reinsert the screws and torque them to 8 foot-pounds. Dimension (A) is 1/16 inch to 1/4 inch.

The center-line of the magnets (B) must align with the center of the sensing head as the Pulser Wrap rotates.

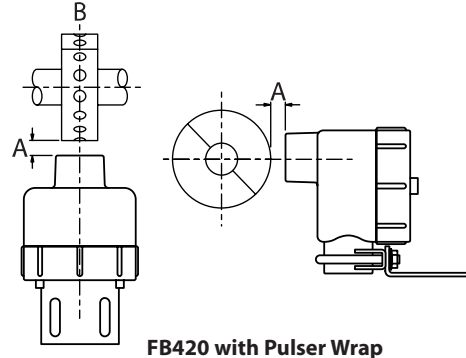

FB420 with Pulser Wrap

Optional EZ-100 EZ-Mount Bracket

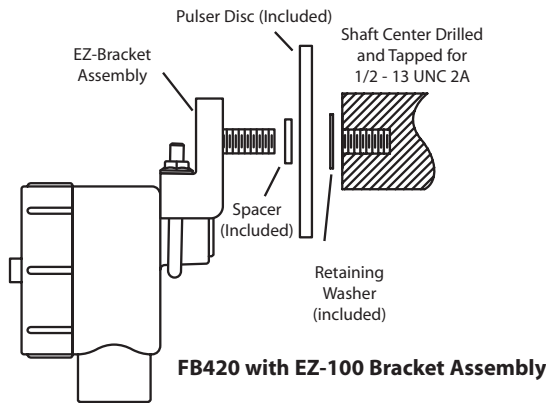

FB420 with EZ-100 Bracket Assembly

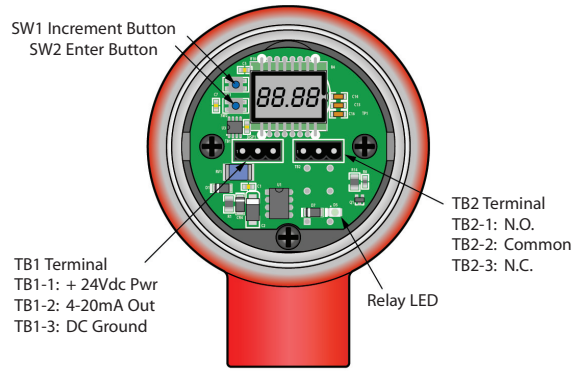

FB420 Rear-View (Cover Removed).
Showing the power/signal terminal TB1, the relay terminal TB2, the push-buttons SW1 and SW2, and the relay LED.

FB420 • Specifications

Input Power

Voltage Requires isolated 24 Vdc \pm 10%
 Current 55 mA with 20 mA signal and relay energized
 External Fuse Requires 0.1A slo-blo

Input Signal

Type Magnetic alternating
 Range of Operation Overall = 0.1Hz to 9999Hz
 (with 8 PPR = 0.75 RPM to 9999* RPM)
 *The LCD can only display up to 9999
 Gap Distance 1/16" to 1/4"

Analog Output Signal

Type 4-20 mA, with programmable end-points: (4 mA @ user's Min RPM) (20 mA @ user's Max RPM)
 Accuracy \pm 0.7%
 4-20 mA Resolution Depends on calibration, but can be a best of 0.001 mA per increment
 Required Impedance 4-20 mA output needs a 250 to 500 Ω load

Specifications subject to change without notice.

Analog Output Signal (cont.)

Max Signal Distance Using a 3-conductor cable with 175 Ω /1000 ft per conductor, the maximum length of cable usable with the FB420 is:
 • 3800 ft when not using the relay
 • 2300 ft. when using the relay

Relay Output Data

Number Available 1 SPDT Form C
 Relay Contact Rating 5 amp @ 30 Vdc, 5 Amp @ 250 Vac
 Relay Functions Fail-safe alarm state is relay de-energized:
 • Unused • Fail-safe Over-speed
 • Fail-safe Under-speed

Physical Environment



Class I, Div I, Group C, D
 Class II Groups E,F,G
 UL File: E249019



Additional Rating NEMA 4X, Gasket Provided
 Operating Temperature -40°C to +65°C (-40°F to +149°F)
 Storage Temperature -40°C to +80°C (-40°F to +176°F)
 Humidity 0% to 90% non-condensing

ES-730 Rev B